

3-5 PINCH ROLLER REPLACEMENT

- 1 Lower the SHEET LOADING LEVER to raise the PINCH ROLLERS.

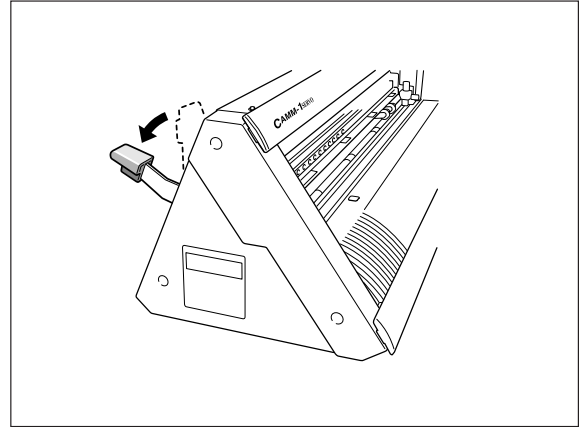

- 2 Remove one of the E-RING with the Flat Head driver.



Set the Sheet to prevent the washer from dropping and going inside the machine during the replacement.

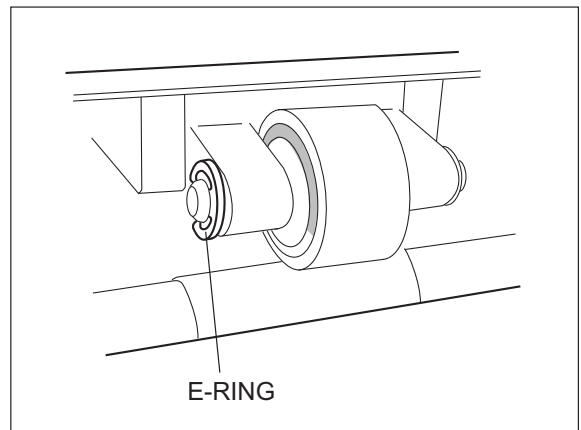

- 3 Remove the SHAFT.

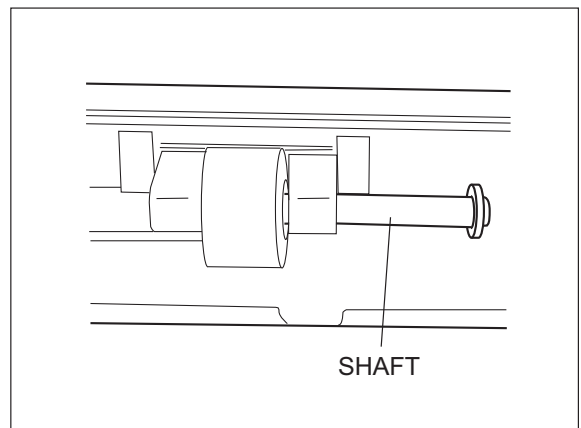

- 4 Fix the new PINCH ROLLER with washers by passing the SHAFT through the PINCH ROLLER.



Be careful with the direction of the PINCH ROLLER. The marked side should be faced outside.

- 5** Fix the E-RING with pincers.

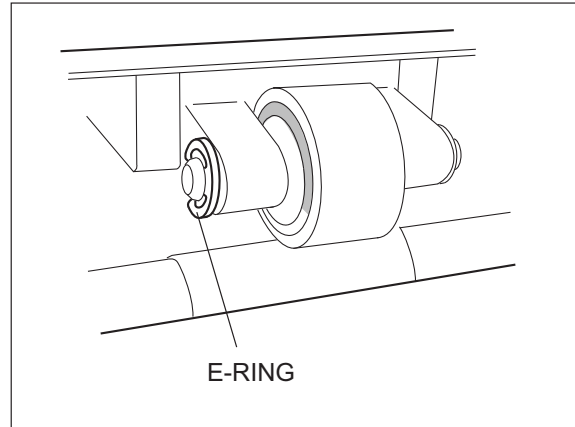

3-6 CUTTER PROTECTION REPLACEMENT

- 1** Put the CUTTER PROTECTION fully from the left edge of the APRON and along the MARK on the CENTER FRAME.

There would be space at the right edge.

