

# SJ-740/540 FJ-540



## Unpacking and Repacking

**CAUTION** Unpacking, and installation must be carried out by four or more persons.  
Failure to do so may result in dropping the unit, leading to injury.

**When attaching these transport bars to the main unit, place rubber feet to face down.**  
Failure to do so may result in pinching hands, leading to injury when moving the main unit.

### How to Unpack

The packings will be needed if you must repack the product. Please do not throw them away.

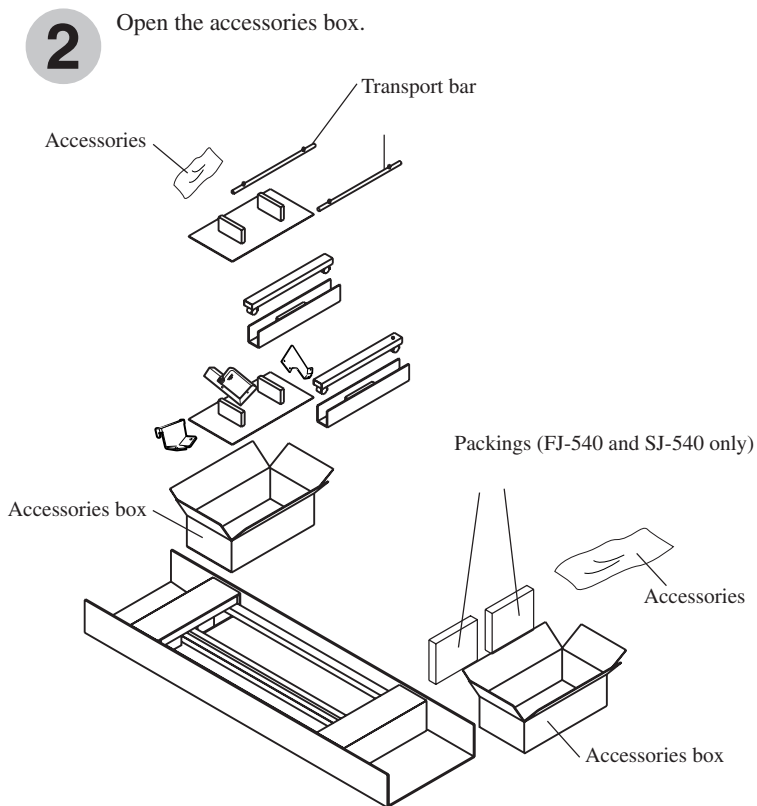
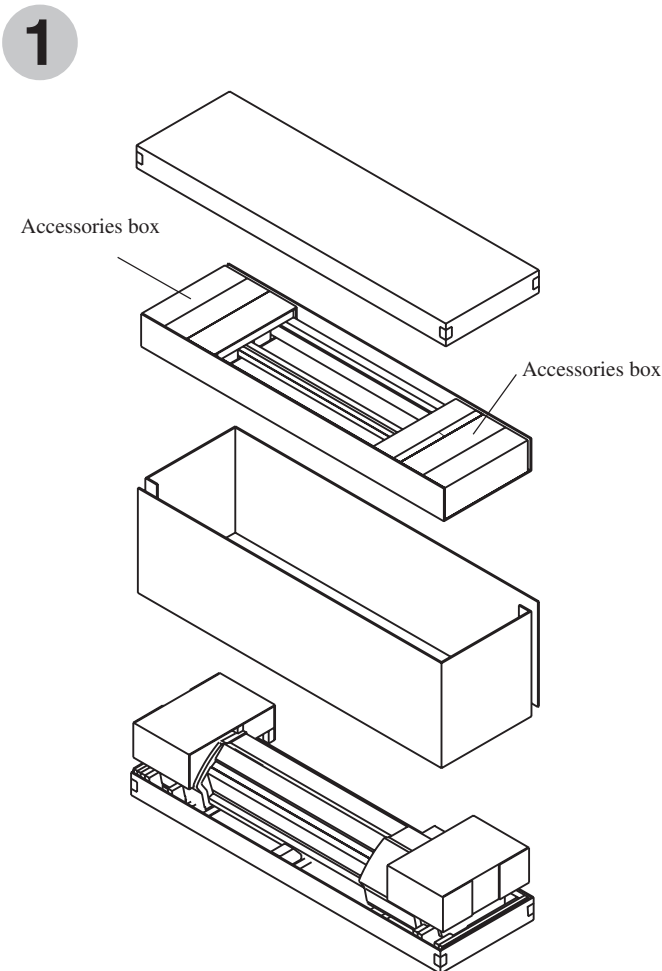

**3** Take out the stand.

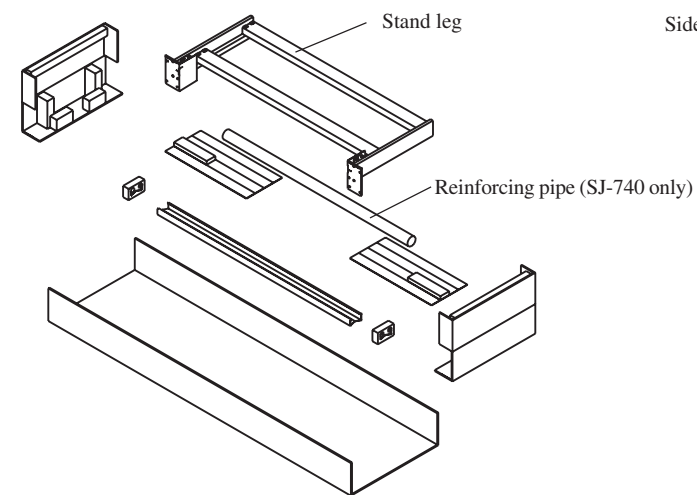

**4** Grip the side of the main unit, and take out it.

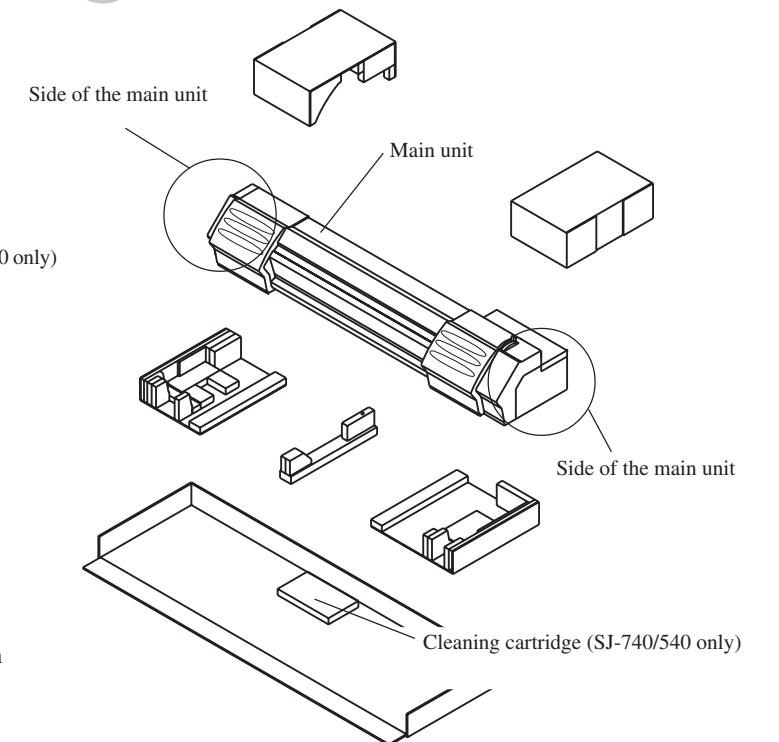

**5** Reading "Getting Started -- Assembling and Installing" in the User's Manual, assemble the machine.



### Moving the Main Unit

Attach these transport bars to the main unit, and move it.

**1** Attach these transport bars at the bottom of the main unit. When doing this, place rubber feet to face down.

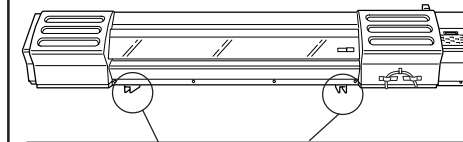

**2** Use the included small bolts to secure.

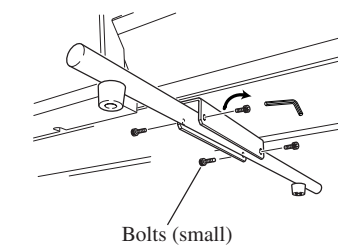

**3** Grip these position in the figure, and move it.

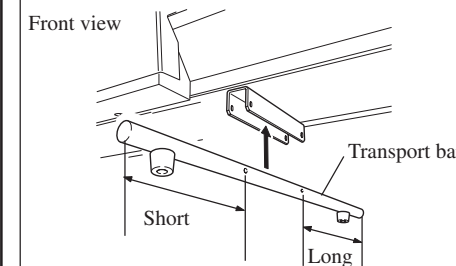
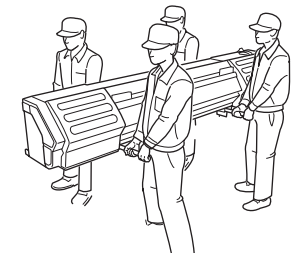

After moving the unit, detach these transport bars in the reverse order of this procedure.

### How to Repack

Please be sure to remove ink as described in the section "Maintenance -- When Moving the Unit" in the User's Manual. Then, repack the machine in the reverse order of this procedure.



22735124-R1

R1-020718