

# MODELA

---

---

# **MDX-40**

## **User's Manual**

---

---

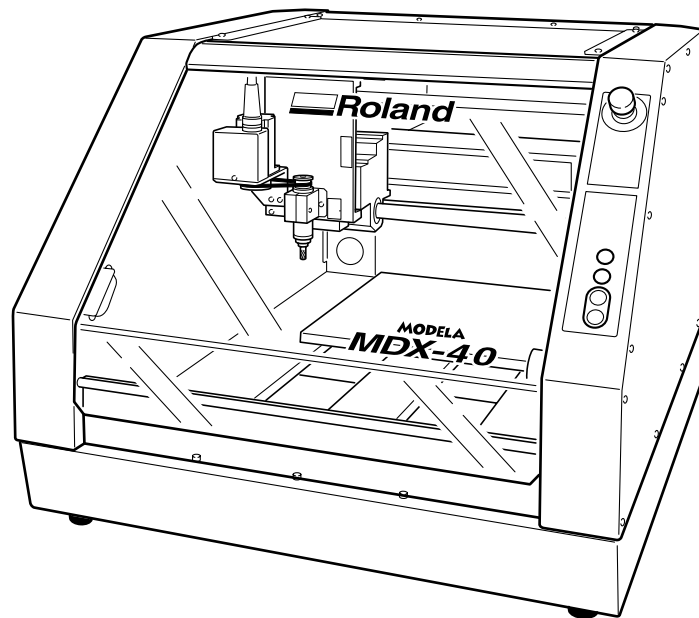

Thank you very much for purchasing this product.

- To ensure correct and safe usage with a full understanding of this product's performance, please be sure to read through this manual completely and store it in a safe location.
- Unauthorized copying or transferral, in whole or in part, of this manual is prohibited.
- The contents of this operation manual and the specifications of this product are subject to change without notice.
- The operation manual and the product have been prepared and tested as much as possible. If you find any misprint or error, please inform us.
- Roland DG Corp. assumes no responsibility for any direct or indirect loss or damage which may occur through use of this product, regardless of any failure to perform on the part of this product.
- Roland DG Corp. assumes no responsibility for any direct or indirect loss or damage which may occur with respect to any article made using this product.

## For the USA

### FEDERAL COMMUNICATIONS COMMISSION RADIO FREQUENCY INTERFERENCE STATEMENT

This equipment has been tested and found to comply with the limits for a Class A digital device, pursuant to Part 15 of the FCC Rules.

These limits are designed to provide reasonable protection against harmful interference when the equipment is operated in a commercial environment.

This equipment generates, uses, and can radiate radio frequency energy and, if not installed and used in accordance with the instruction manual, may cause harmful interference to radio communications.

Operation of this equipment in a residential area is likely to cause harmful interference in which case the user will be required to correct the interference at his own expense.

---

Unauthorized changes or modification to this system can void the users authority to operate this equipment.

The I/O cables between this equipment and the computing device must be shielded.

## For Canada

### CLASS A NOTICE

This Class A digital apparatus meets all requirements of the Canadian Interference-Causing Equipment Regulations.

### CLASSE A AVIS

Cet appareil numérique de la classe A respecte toutes les exigences du Règlement sur le matériel brouilleur du Canada.

## NOTICE

### Grounding Instructions

Do not modify the plug provided - if it will not fit the outlet, have the proper outlet installed by a qualified electrician.

Check with qualified electrician or service personnel if the grounding instructions are not completely understood, or if in doubt as to whether the tool is properly grounded.

Use only 3-wire extension cords that have 3-prong grounding plugs and 3-pole receptacles that accept the tool's plug.

Repair or replace damaged or worn out cord immediately.

### Operating Instructions

**KEEP WORK AREA CLEAN.** Cluttered areas and benches invites accidents.

**DON'T USE IN DANGEROUS ENVIRONMENT.** Don't use power tools in damp or wet locations, or expose them to rain. Keep work area well lighted.

**DISCONNECT TOOLS** before servicing; when changing accessories, such as blades, bits, cutters, and like.

**REDUCE THE RISK OF UNINTENTIONAL STARTING.** Make sure the switch is in off position before plugging in.

**USE RECOMMENDED ACCESSORIES.** Consult the owner's manual for recommended accessories. The use of improper accessories may cause risk of injury to persons.

**NEVER LEAVE TOOL RUNNING UNATTENDED. TURN POWER OFF.** Don't leave tool until it comes to a complete stop.



### ROLAND DG CORPORATION

1-6-4 Shinmiyakoda, Hamamatsu-shi, Shizuoka-ken, JAPAN 431-2103

MODEL NAME : See the MODEL given on the rating plate.

RELEVANT DIRECTIVE : EC MACHINERY DIRECTIVE (98/37/EC)



EC LOW VOLTAGE DIRECTIVE (73/23/EEC)

EC ELECTROMAGNETIC COMPATIBILITY DIRECTIVE (89/336/EEC)

## WARNING

This is a Class A product. In a domestic environment this product may cause radio interference in which case the user may be required to take adequate measures.

# Contents

 To Ensure Safe Use .....	3
 Pour utiliser en toute sécurité .....	8
<b>Important Notes on Handling and Use .....</b>	<b>13</b>
<b>Chapter 1 Introduction .....</b>	<b>15</b>
1-1 About This Machine .....	16
What You Can Do with This Machine .....	16
Operation Screen .....	16
Part Names and Functions .....	17
The Machine's Coordinate Systems .....	20
<b>Chapter 2 Preparation .....</b>	<b>21</b>
2-1 Included Items .....	22
2-2 Installation .....	23
Installation Environment .....	23
Installation Space .....	23
Removing the Retainers .....	24
Connecting the Power Cord .....	25
Installing the Windows-based Driver and Connecting to the Computer .....	26
<b>Chapter 3 Operation .....</b>	<b>27</b>
3-1 Switching the Power On and Off .....	28
Starting the System .....	28
Switching Off the Power .....	29
3-2 Emergency Stop to Ensure Safety .....	30
Emergency stop switch .....	30
Front Cover .....	30
3-3 Installing a Tool and Setting the Cutting-start Location .....	31
The Locations of the Origin Points .....	31
Installing a Tool .....	31
Setting the Cutting-start Location .....	32
3-4 Starting Cutting .....	33
3-5 Stopping and Pausing Cutting .....	34
Pausing Cutting .....	34
Stopping Cutting .....	34
<b>Chapter 4 Feature Reference .....</b>	<b>35</b>
4-1 Setting the Z Origin Using the Sensor .....	36
Setting the Z origin on the Workpiece .....	36
4-2 Installing the Engraving Cutter .....	38
Installing a Cutter and Setting the Origin Point for Machining .....	38
<b>Chapter 5 Appendix .....</b>	<b>41</b>
5-1 Maintenance .....	42
Daily Care .....	42
Spindle Inspection .....	42
5-2 What to Do If .....	43
The machine doesn't run. ....	43
The cutting results are not attractive. ....	43
What to Do If a Flashing Error Is Displayed .....	43
What to Do If an Error Message Appears .....	43

## Contents

---

5-3 Locations of the Power Rating and Serial Number Labels .....	45
5-4 Specifications .....	46
Main Unit Specification .....	46
Expansion Connector Specification .....	47

Company names and product names are trademarks or registered trademarks of their respective holders.



Copyright© 2004 Roland DG Corporation

<http://www.rolanddg.com/>







# To Ensure Safe Use

Improper handling or operation of this machine may result in injury or damage to property. Points which must be observed to prevent such injury or damage are described as follows.

## About WARNING and CAUTION Notices

 <b>WARNING</b>	Used for instructions intended to alert the user to the risk of death or severe injury should the unit be used improperly.
 <b>CAUTION</b>	Used for instructions intended to alert the user to the risk of injury or material damage should the unit be used improperly. * Material damage refers to damage or other adverse effects caused with respect to the home and all its furnishings, as well to domestic animals or pets.

## About the Symbols

	The  symbol alerts the user to important instructions or warnings. The specific meaning of the symbol is determined by the design contained within the triangle. The symbol at left means "danger of electrocution."
	The  symbol alerts the user to items that must never be carried out (are forbidden). The specific thing that must not be done is indicated by the design contained within the circle. The symbol at left means the unit must never be disassembled.
	The  symbol alerts the user to things that must be carried out. The specific thing that must be done is indicated by the design contained within the circle. The symbol at left means the power-cord plug must be unplugged from the outlet.

 **Incorrect operation may cause injury**

 **WARNING**



**Do not disassemble, repair, or modify.**  
Doing so may lead to fire or abnormal operation resulting in injury.



**Never allow children near the machine.**  
The machine includes locations and components that pose a danger to children, and major accident, including injury, blindness, or choking, may occur.

 **CAUTION**



**Be sure to follow the operation procedures described in this manual.**  
Failure to follow the procedures may cause sudden operation or the like of the machine, which may result in unexpected injury.



**Never allow anyone unfamiliar with the usage or handling of the machine to touch the machine.**  
Touching a dangerous location may cause sudden operation or the like of the machine, which may lead to an unexpected accident.



**Never operate if a front cover is cracked or broken.**  
Doing so may result in injury. If the front cover is cracked, contact your authorized Roland DG Corp. dealer or service center.

 **This machine weighs approximately 70 kg (155 lb.).**

 **CAUTION**



**Unpacking, installation, and moving are operations that must be carried out by four or more persons.**  
Failure to do so may result in falling of the unit, leading to injury.





**Install on a stable surface.**  
Failure to do so may result in the unit tipping over, leading to injury.

** Danger of electrical short, shock, electrocution, or fire**

** WARNING**

 **Do not use with any electrical power supply that does not meet the ratings displayed on the unit.**  
Use with any other power supply may lead to fire or electrocution.

 **Ground the unit with the ground wire.**  
Failure to do so may result in risk of electrocution in the event of a mechanical problem.

 **Never allow the machine to get wet, or apply gasoline, thinner, or any other flammable material to it.**  
Current leakage may cause electrical shock, electrocution, or combustion and fire.

 **Never allow hairpins, coins, matches, or any other object to get inside the machine through the ventilation ports.**  
Doing so may cause an electrical short, resulting in shock or electrocution, or the inserted object may catch fire.

 **Never place gasoline, alcohol, thinner, or any other flammable material near the machine, or use an aerosol spray close to the machine.**  
Doing so may cause fire.

 **Never operate in locations such as those near an open flame or heater, or where sparking or static electricity may occur.**  
Cuttings or the like may ignite and cause fire.

 **Never damage the power cord or pull it with force.**  
Doing so may tear the cord's insulation, causing an electrical short and resulting in electrical shock, electrocution, or fire.

 **Never place any object on the power cord, bend the power cord using excessive force, or allow the power cord to become deformed.**  
If it becomes deformed, the deformed location may grow hot and cause fire.

 **Never use the machine with the power cord bound into a bundle or roll.**  
If the cord is in a bundle or roll, it may grow hot and cause fire.

 **Do not use with a damaged power cord or plug, or with a loose electrical outlet.**  
Doing so may lead to fire, electrical shock, or electrocution.

 **Never use any power cord other than the power cord included with the machine. Also, never use a power strip or extension cord.**  
The power strip or extension cord may grow hot and cause fire.

 **In the event of an abnormal state (such as smoke or sparks, odor or burning or unusual noise), immediately unplug the power cord.**  
Failure to do so may result in fire, electrical shock, or electrocution. Immediately disconnect the power cord and contact your Roland DG Corp. service center.

 **When not in use for extended periods, unplug the power-cord plug from the electrical outlet.**  
Failure to do so may result in danger of electrical shock, electrocution, or fire due to deterioration of electrical insulation.

 **Never operate the machine or insert or remove its power plug with wet hands.**  
Doing so may result in electrical shock or electrocution.





 **When unplugging the electrical power cord from the power outlet, grasp the plug, not the cord.**  
Unplugging by pulling the cord may damage it, leading to fire, electrical shock, or electrocution.

 **Important Notes on Cutting**

 **WARNING**

-  **Never use an air gun (blower) to remove cuttings.**  
Using an air gun (blower) may blow cuttings inside the machine, creating a fire hazard.

 **CAUTION**

-  **Do not touch the tip of the cutting tool with your fingers.**  
Doing so may result in injury.
-  **Perform dry cutting with no cutting oil.**  
Such materials can cause fire.
-  **When you're finished, wash your hands to rinse away all cuttings.**
-  **Do not touch the spindle motor immediately after a cutting operation has ended.**  
Doing so may result in burns.



## ⚠ Warning Labels

Warning labels are affixed to make areas of danger immediately clear. The meanings of these labels are as follows. Be sure to heed their warnings. Also, never remove the labels or allow them to become obscured.

**Caution: Pinching Hazard**  
Contact during operation may caused the hand or fingers to become pinched, resulting in injury.



**▲ CAUTION**  
Please use a vacuum cleaner to remove cutting dust. Do not use any blower like airbrush. Otherwise, dust spread in the air may harm your health or damage this machine.

**▲ PRECAUCION**  
Por favor, utilice un aspirador para limpiar la viruta y el polvo. No utilice aire a presión para la limpieza, podría averiar la máquina, y no sería conveniente para su salud respirar el polvo.

**▲ PRUDENCE**  
Veuillez utiliser un aspirateur pour enlever la poussière. Ne jamais utiliser de projecteurs d'air. La poussière soufflée dans l'air peut causer des problèmes de respiration et endommager votre machine.

**▲ VORSICHT**  
Bitte entfernen Sie Staub mit einem Staubsauger. Niemals ein Gebläse verwenden. Der dadurch freigesetzte Staub ist gesundheitsschädlich und kann die Funktion Ihres Geräts beeinträchtigen.

**▲ CAUTELA**  
Usare un aspiratore per rimuovere polvere o trucioli da lavorazione. Non usare compressori, altrimenti la polvere diffusa nell'aria potrebbe essere nociva alla salute o danneggiare la macchina.

**▲ 注意**  
切削粉は吸い込み型のクリーナーを使用して除去して下さい。吹き飛ばすエアガンは使用しないで下さい。切削粉が空気中に舞い散ると健康被害の原因になったり、機体に侵入し故障の原因となります。

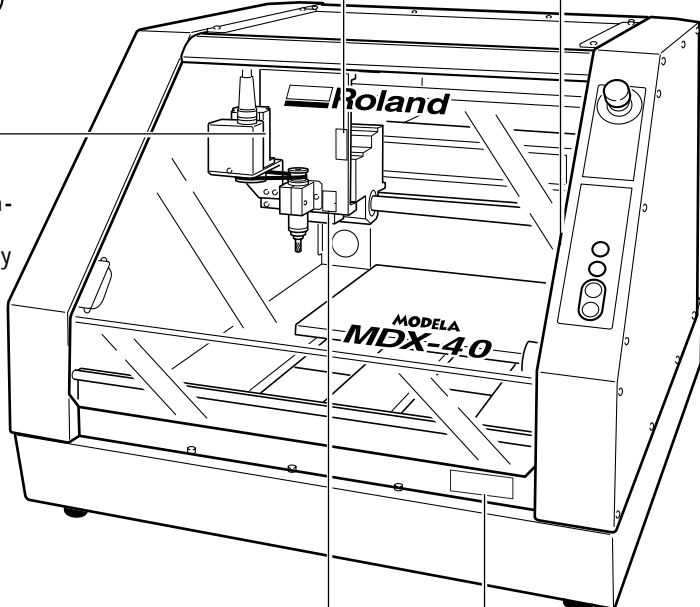

**Caution: High Temperature**  
Never touch immediately after cutting operation.



To reduce the risk of Injury, user must read and understand user's manual.





**Caution: Sharp Tool**  
Inadvertent contact may cause injury.









# Pour utiliser en toute sécurité

La manipulation ou l'utilisation inadéquates de cet appareil peuvent causer des blessures ou des dommages matériels. Les précautions à prendre pour prévenir les blessures ou les dommages sont décrites ci-dessous.

## Avis sur les avertissements

 <b>ATTENTION</b>	Utilisé pour avertir l'utilisateur d'un risque de décès ou de blessure grave en cas de mauvaise utilisation de l'appareil.
 <b>PRUDENCE</b>	Utilisé pour avertir l'utilisateur d'un risque de blessure ou de dommage matériel en cas de mauvaise utilisation de l'appareil.  * Par dommage matériel, il est entendu dommage ou tout autre effet indésirable sur la maison, tous les meubles et même les animaux domestiques.

## À propos des symboles

	Le symbole  attire l'attention de l'utilisateur sur les instructions importantes ou les avertissements. Le sens précis du symbole est déterminé par le dessin à l'intérieur du triangle. Le symbole à gauche signifie "danger d'électrocution".
	Le symbole  avertit l'utilisateur de ce qu'il ne doit pas faire, ce qui est interdit. La chose spécifique à ne pas faire est indiquée par le dessin à l'intérieur du cercle. Le symbole à gauche signifie que l'appareil ne doit jamais être démonté.
	Le symbole  prévient l'utilisateur sur ce qu'il doit faire. La chose spécifique à faire est indiquée par le dessin à l'intérieur du cercle. Le symbole à gauche signifie que le fil électrique doit être débranché de la prise.

 **L'utilisation incorrecte peut causer des blessures**

 **ATTENTION**



**Ne pas démonter, réparer ni modifier.**

Démonter, réparer ou modifier l'appareil risque de provoquer un incendie ou de causer un fonctionnement anormal entraînant des blessures.



**Ne jamais laisser d'enfants s'approcher de l'appareil.**

Des éléments et des surfaces de l'appareil présentent des risques pour les enfants. Il pourrait se produire un accident grave qui causerait des blessures, ou créerait un risque de cécité ou de suffocation.

 **PRUDENCE**



**S'assurer de suivre les procédures d'utilisation décrites dans ce manuel.**

Si les procédures indiquées ne sont pas suivies, le fonctionnement de l'appareil peut être déclenché soudainement, ce qui risque de causer des blessures.



**Ne jamais permettre à quiconque de toucher l'appareil s'il ou si elle n'en connaît pas le fonctionnement ou la maintenance.**

Toucher l'appareil à certains points dangereux peut en déclencher le fonctionnement, ce qui risque de causer un accident imprévu.



**Ne pas utiliser si un couvercle avant est fissuré ou brisé.**

Si le couvercle transparent à l'avant ou sur le côté de l'appareil est fissuré, communiquer avec le revendeur ou le centre de service autorisés de la société Roland DG.

 **Le poids de cet appareil est d'environ 70 kg (155 lb.)**

 **ATTENTION**



**Lorsque vous déplacez l'appareil, le saisir par sa base en aluminium et le transporter à 4 personnes ou plus.**

Tirer sur le fil peut l'endommager, ce qui risque de provoquer un incendie ou de causer une décharge électrique ou une électrocution.





**Installer sur une surface stable.**

Sinon, l'appareil risque de se renverser et de causer des blessures.

 **Risque de décharge ou de choc électrique, d'électrocution ou d'incendie**

 **ATTENTION**

 **Ne pas utiliser avec une source d'alimentation électrique non conforme à la norme indiquée sur l'appareil.**  
Utiliser l'appareil avec une autre source d'alimentation risque de provoquer un incendie ou de causer une électrocution.

 **Mettre l'appareil à la terre avec le fil de mise à la terre.**  
Ne pas respecter cette consigne peut créer un risque d'électrocution en cas de panne mécanique.

 **Ne jamais permettre que l'appareil soit mouillé; ne jamais y appliquer d'essence, de diluant ni aucun matériau inflammable.**  
Une fuite de courant peut causer un choc électrique, l'électrocution ou la combustion et un incendie.

 **Ne jamais laisser des épingles à cheveux, des pièces de monnaie, des allumettes ni aucun autre objet pénétrer dans l'appareil par les orifices de ventilation.**  
Cela crée un risque de décharge électrique ou d'électrocution. En outre, les objets peuvent prendre feu.

 **Ne jamais endommager le câble d'alimentation ni le tirer vigoureusement.**  
Cela risque de déchirer l'isolant du câble et de causer un court-circuit, ce qui aurait comme résultat un choc électrique, l'électrocution ou un incendie.

 **Ne jamais placer de l'essence, du diluant ni aucun matériau inflammable près de l'appareil; ne jamais utiliser de produits en aérosol près de l'appareil.**  
Cela crée un risque d'incendie.

 **Ne jamais utiliser l'appareil près d'une flamme nue ou d'un appareil de chauffage ou dans des endroits où la production d'étincelles ou d'électricité statique peut survenir.**  
Les copeaux ou les autres produits combustibles peuvent s'enflammer et causer un incendie.

 **Ne jamais placer d'objets sur le cordon d'alimentation, plier le câble d'alimentation en utilisant une force excessive ni laisser le câble d'alimentation se déformer.**  
Si le câble se déforme, la section affectée peut surchauffer et causer un incendie.

 **Ne jamais utiliser l'appareil si le câble d'alimentation est attaché ou enroulé.**  
S'il est attaché ou enroulé, il peut surchauffer et causer un incendie.

 **Ne pas utiliser si le fil ou la fiche électriques sont endommagés; ne pas brancher dans une prise mal fixée.**  
Négliger de suivre cette consigne risque de provoquer un incendie ou de causer une décharge électrique ou une électrocution.

 **Ne jamais utiliser un cordon d'alimentation autre que celui qui est fourni avec l'appareil. Ne jamais non plus utiliser de bande d'alimentation électrique ni de rallonge.**  
La bande d'alimentation ou la rallonge peuvent surchauffer et causer un incendie.

 **S'il se produit quoi que ce soit d'anormal (fumée, étincelles, odeur, combustion ou bruit inhabituel), débrancher immédiatement le câble d'alimentation.**  
Le défaut de ce faire peut entraîner un incendie, un choc électrique ou l'électrocution. Débrancher immédiatement le câble d'alimentation et communiquer avec le Centre de services Roland DG.

 **Si l'appareil reste inutilisé pendant de longues périodes, débrancher la fiche de la prise.**  
Négliger de suivre cette consigne peut créer un risque de décharge électrique ou d'électrocution ou provoquer un incendie à cause de la détérioration de l'isolant électrique.

## ATTENTION

-  **Ne jamais utiliser l'appareil, insérer la prise dans le réceptacle ou l'en enlever si on a les mains mouillées.**  
Il y a risque de décharge électrique ou d'électrocution.





-  **Pour débrancher l'appareil, saisir la fiche et non le fil électrique.**  
Tirer sur le fil peut l'endommager, ce qui risque de provoquer un incendie ou de causer une décharge électrique ou une électrocution.

## Remarques importantes sur la coupe

### ATTENTION

-  **Utiliser un aspirateur pour nettoyer.**  
Un canon à air (souffleuse) peut projeter des copeaux à l'intérieur de l'appareil et créer un risque d'incendie.

### PRUDENCE

-  **Ne pas toucher à l'extrémité de la lame avec vos doigts.**  
Vous risqueriez de vous blesser en y touchant.
-  **Faire des coupes à sec, sans huile de coupe.**  
L'huile de coupe peut provoquer un incendie.
-  **Quand vous avez terminé d'utiliser l'appareil, laver vos mains pour bien enlever tous les copeaux.**
-  **Ne touchez pas le moteur de l'axe immédiatement après avoir terminé une coupe.**  
Vous risqueriez alors de vous brûler.

## ⚠ Vignettes d'avertissement

Des vignettes d'avertissement sont apposées pour qu'il soit facile de repérer les zones dangereuses. La signification des vignettes est donnée ci-dessous. Respecter les avertissements. Ne jamais retirer les vignettes et ne pas les laisser s'encrasser.

**Attention : risque de pincement**  
Un contact pendant le fonctionnement peut coincer la main ou les doigts ce qui risque de causer des blessures.



**Attention : température élevée**  
Ne jamais toucher immédiatement après une opération de coupe.

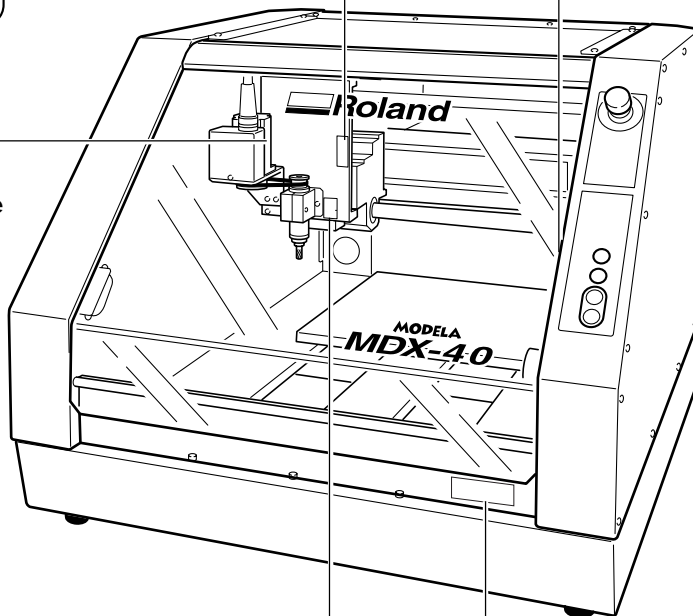

<b>⚠ CAUTION</b> Please use a vacuum cleaner to remove cutting dust. Do not use any blower like airbrush. Otherwise, dust spread in the air may harm your health or damage this machine.	<b>⚠ VORSICHT</b> Staub entfernen Sie Staub mit einem Staubsauger. Niemals ein Gebläse verwenden. Der dadurch freigesetzte Staub ist gesundheitsschädlich und kann die Funktion Ihres Geräts beeinträchtigen.
<b>⚠ PRECAUCION</b> Por favor, utilice un aspirador para limpiar la viruta y el polvo. No utilice aire a presión para la limpieza, podría averiar la máquina, y no sería conveniente para su salud respirar el polvo.	<b>⚠ CAUTELA</b> Usare un aspiratore per rimuovere polvere o trucioli da lavorazione. Non usare compressori, altrimenti la polvere diffusa nell'aria potrebbe essere nociva alla salute o danneggiare la macchina.
<b>⚠ PRUDENCE</b> Veuillez utiliser un aspirateur pour enlever la poussière. Ne jamais utiliser de projecteurs d'air. La poussière soufflée dans l'air peut causer des problèmes de respiration et endommager votre machine.	<b>⚠ 注意</b> 切粉粉は吸い込み型のクリーナーを使用して除去して下さい。吹き飛ばすエアガンは使用しないで下さい。切粉粉が飛び回り健康被害になったり、機体に侵入し故障の原因となります。



**AVERTISSEMENT :**  
Afin de réduire le risque de blessures, l'utilisateur doit lire et bien comprendre le mode d'emploi.

**Attention : outil coupant**  
Un contact imprudent risque d'entraîner une blessure.

# Important Notes on Handling and Use

This machine is a precision device. To ensure the full performance of this machine, be sure to observe the following important points. Failure to observe these may not only result in loss of performance, but may also cause malfunction or breakdown.

---

## ***This Machine Is a Precision Device***

---

- Handle carefully, and never subject the machine to impact or excessive force.
- Never needlessly insert your hand or fingers inside the mechanical areas, including the areas inside the spindle and under the table.

---

## ***Install in a Suitable Location***

---

- Install in a location having the specified temperature and relative humidity.
- Install in a quiet, stable location offering good operating conditions.

---

## ***The tip of the tool is breakable***

---

- Handle with care, being careful not to drop it.

---

## ***Clean carefully.***

---

- Excessive buildup of cuttings may impede correct operation and cause malfunction.

---

## ***This machine becomes hot.***

---

- Never cover or block the ventilation holes with cloth, tape, or any other material.
- Install in a well-ventilated location.

---

## ***This machine is suited to cutting resins.***

---

- Never use it to cut metal.





# ***Chapter 1***

## ***Introduction***

---

# 1-1 About This Machine

## What You Can Do with This Machine

This is a high-speed, high-efficiency modeling machine. You can cut three-dimensional text and shapes by outputting data from the program included with the machine or from the CAD program you're using.

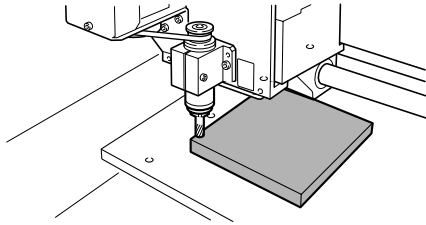

## Operation Screen

To make the settings for cutter movement and the cutting-start location, you use the Windows-based driver. To operate the machine, display the operation panel screen.

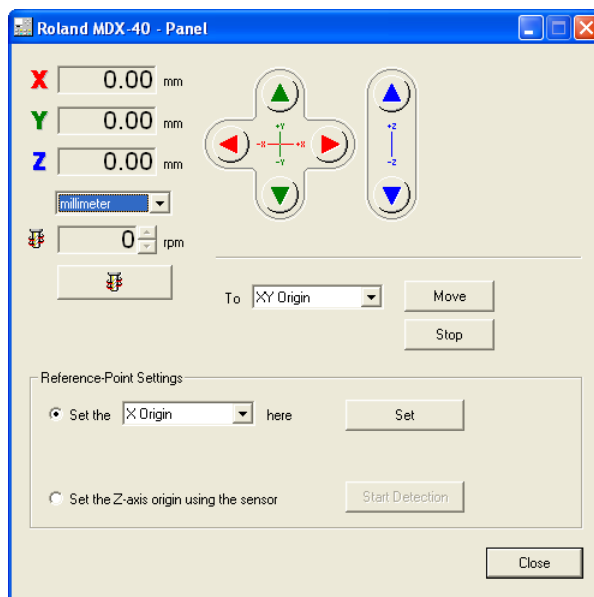

## Part Names and Functions

### Front View

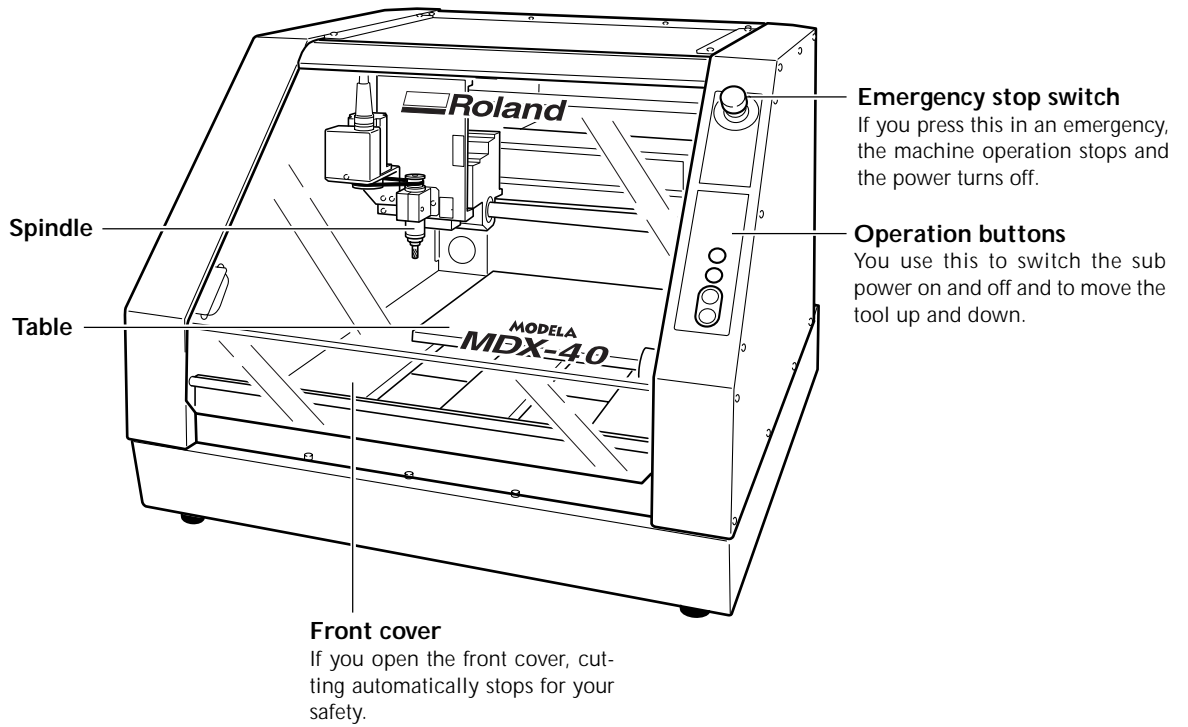

### Spindle

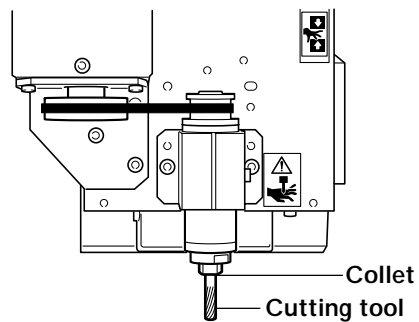

Side view

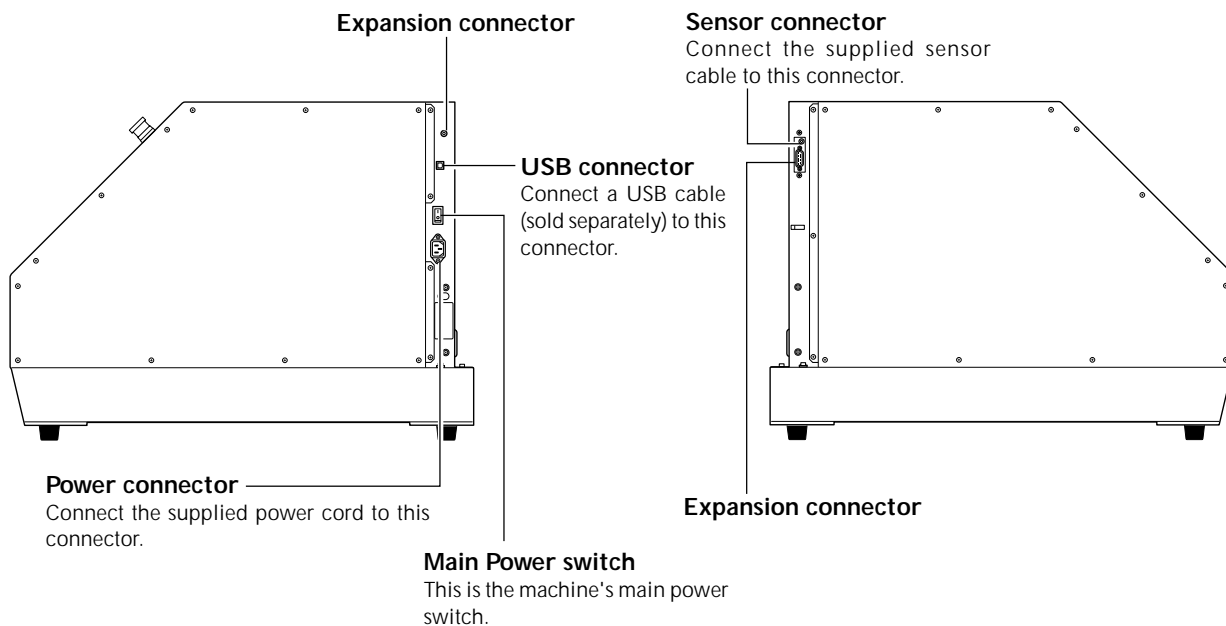

Operation buttons

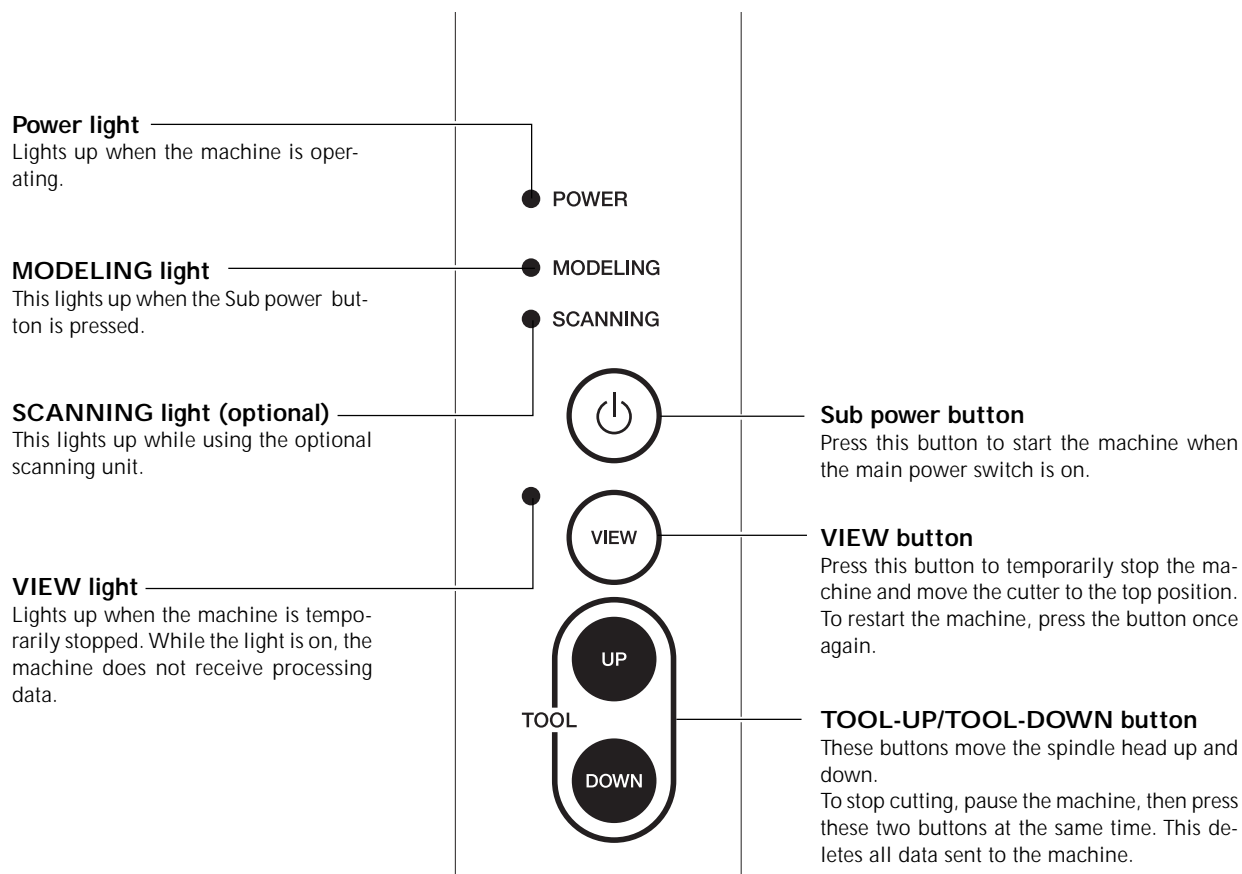

**Operation panel screen**

To make the settings for cutter movement and the cutting-start location, you use the Windows-based driver. To operate the machine, display the operation panel screen.

**X-, Y-, and Z-axis coordinates**

These display the present coordinate values (workpiece coordinate system) for the X, Y, and Z axes.

**Unit of measurement for display**

This switches the measurement unit for the window display to millimeters, inches, or steps.

**Spindle-rotation**

This set the rotation of the spindle.

**Spindle-rotation button**

This switches spindle rotation on and off.

**XYZ movement buttons**

These move the spindle in the X, Y, and Z directions.

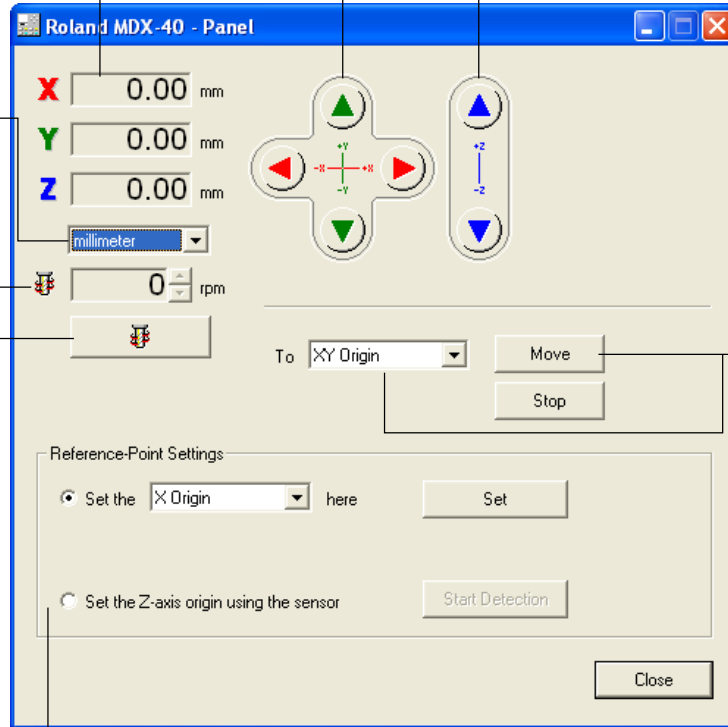

**Moving to the Specified Location**

This moves to the specified location in a single step. You can quit moving by clicking [Stop].

**Reference-Point Settings**

These set the cutting-start location. You use these to set the origin point at the selected location and to detect the selected origin.

## The Machine's Coordinate Systems

You can freely change the locations of the origin points for this machine. The coordinate values for the axes are referenced to these origin points. Changing the locations of the origins makes the coordinate values change as well. This kind of coordinate system is called a "workpiece coordinate system."

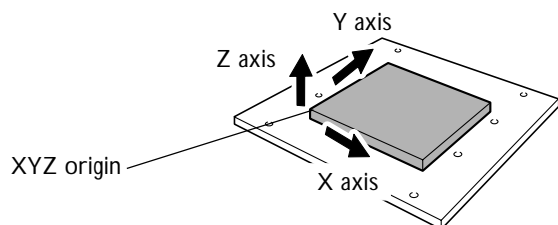

# ***Chapter 2***

## ***Preparation***

---

## 2-1 Included Items

The following items are included with the machine. Make sure they are all present and accounted for.

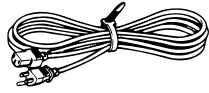

Power cord

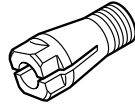

Collet



Sensor

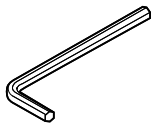

Hexagonal wrench

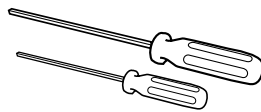

Hexagonal screw drivers



Spanners

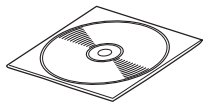

Roland Software Package  
CD-ROM

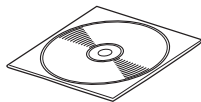

MODELA Player4  
CD-ROM

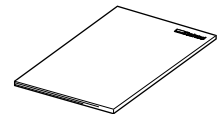

User's Manual (this document)

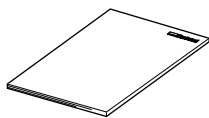

Roland Software Package  
Installation and Setup Guide

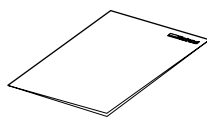

MODELA Player 4  
Installation and Setup Guide



# 2-2 Installation

## Installation Environment

- ⚠️ WARNING** Never install in a location exposed to water or to gasoline, thinner, or any other flammable material.  
Current leakage may cause electrical shock, electrocution, or combustion and fire.
- ⚠️ WARNING** Never place gasoline, alcohol, thinner, or any other flammable material near the machine. Also, never use an aerosol spray near the machine.  
Doing so may cause fire.
- ⚠️ WARNING** Never operate in a location such as one near an open flame or heater, or where sparking or static electricity may occur.  
Cuttings or the like may ignite and cause fire.
- ⚠️ CAUTION** Install on a stable surface.  
Failure to do so may result in the unit tipping over, leading to injury.

### Unsuitable Installation Sites

- > Locations subject to large fluctuations in temperature or humidity
- > Locations subject to shaking or vibration
- > Locations where the floor is tilted, not level, or unstable
- > Dusty locations
- > Locations exposed to direct sunlight or near air-conditioning or heating equipment
- > Locations exposed to considerable electrical or magnetic noise, or other forms of electromagnetic energy

## Installation Space

700 (W) x 800 (D) x 600 (H) mm (28 (W) x 32 (D) x 24 (H) in.)

## Removing the Retainers

Retainers are attached to the machine to protect it from vibration during transportation. When installation is complete, remove these.

**⚠ CAUTION** Perform this task with all power switches left switched off. Otherwise sudden movement of the machine may cause injury.

- Remove all retainers. Any that remain may cause faulty operation or breakdown when the power is switched on.
- Store these retainers carefully, because they are needed again when transporting the machine for relocation or the like.

- ➊ Remove the screws shown in the figure, then detach these retainers.
- ➋ Mount the screws at its original location on the machine.

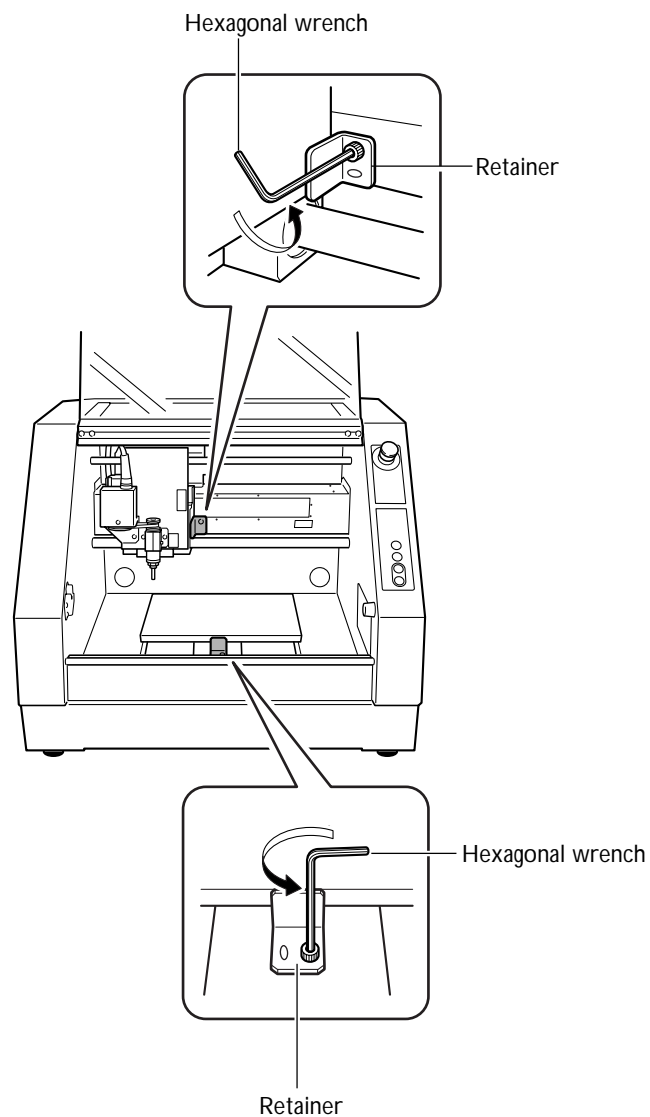

## Connecting the Power Cord

- ⚠ WARNING** Do not use with any electrical power supply that does not meet the ratings displayed on the unit.  
Use with any other power supply may lead to fire or electrocution.
- ⚠ WARNING** Ground the unit with the ground wire.  
Failure to do so may result in risk of electrocution in the event of a mechanical problem.
- ⚠ CAUTION** Perform this task with all power switches left switched off.  
Otherwise sudden movement of the machine may cause injury.

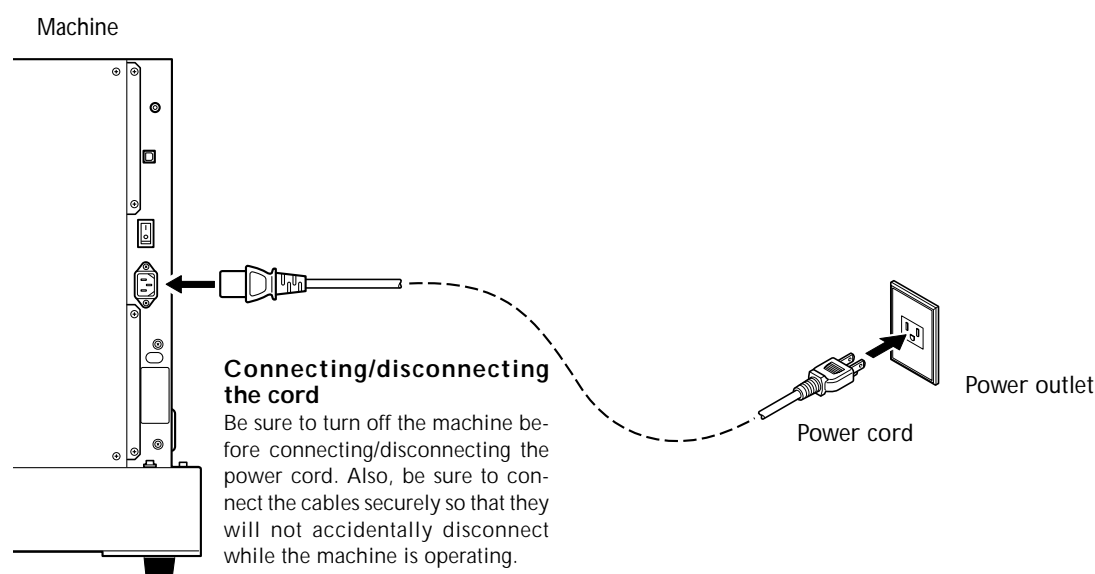

### Important Notes on the Power Cord

- ⚠ WARNING** Never damage the power cord or pull it with force.  
Doing so may tear the cord's insulation, causing an electrical short and resulting in electrical shock, electrocution, or fire.
- ⚠ WARNING** Never place any object on the power cord, bend the power cord using excessive force, or allow the power cord to become deformed.  
If it becomes deformed, the deformed location may grow hot and cause fire.
- ⚠ WARNING** Never use the machine with the power cord bound into a bundle or roll.  
If the cord is in a bundle or roll, it may grow hot and cause fire.
- ⚠ WARNING** Never use any power cord other than the power cord included with the machine. Also, never use a power strip or extension cord.  
The power strip or extension cord may grow hot and cause fire.
- ⚠ WARNING** Do not use with a damaged power cord or plug, or with a loose electrical outlet.  
Doing so may lead to fire, electrical shock, or electrocution.

## Installing the Windows-based Driver and Connecting to the Computer

- Installing the driver following "Roland Software Package Installation and Setup Guide"
- Be sure to make the connection between the machine to the computer during the course of installing the driver. If the cable connection is made before you start installation of the driver, driver installation may fail and the machine may become unusable.
- Use a shielded USB cable having a length of 3 meters or less.
- Do not use a USB hub or the like.

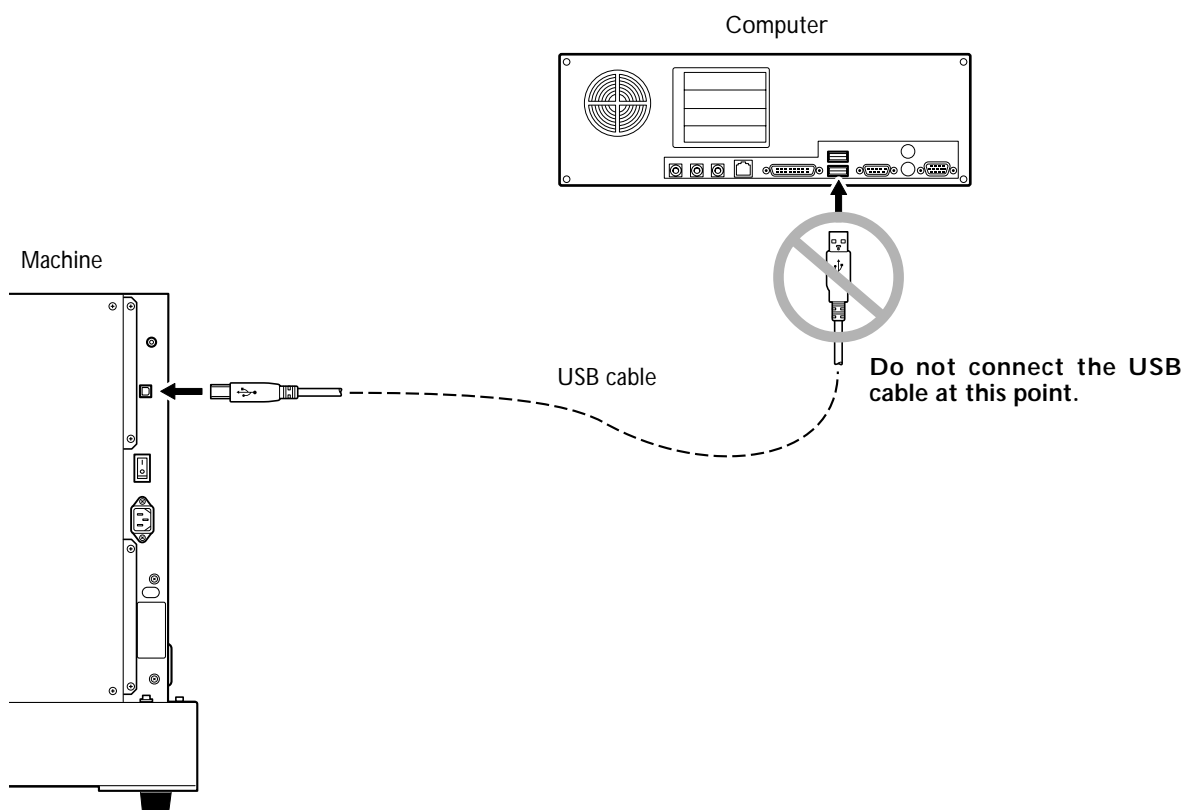

# *Chapter 3*

# *Operation*

---

# 3-1 Switching the Power On and Off

## Starting the System

### 1. Start the machine.

1

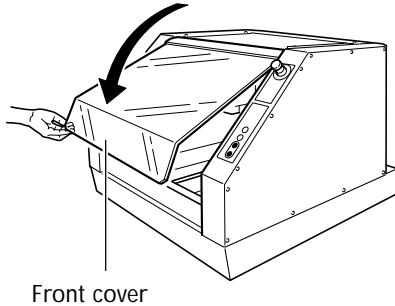

Close the front cover.

2

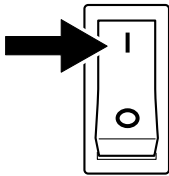

Switch on the main power switch.  
The POWER light comes on.

3

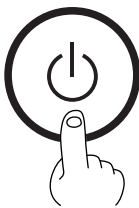

Press the Sub power button.  
The machine starts up, and initialization is performed.  
After initialization ends, the MODELING light and the VIEW light comes on and the machine is paused.

4

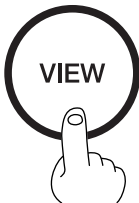

Press the VIEW button.  
The view state is canceled, and the machine finishes preparations for receiving cutting data.

## 2. Start the operation panel screen.

Open the operation panel screen.

From the operation panel screen, you can make the settings for cutter movement and the start location for cutting.

### ① If You're Using Windows XP

From the [Start] menu, click [Control Panel].

Click [Printers and Other Hardware], then click [Printers and Faxes].

### If You're Using Windows 98/Me/2000

From the [Start] menu, click [Settings], then [Printers].

②



Right-click the [Roland MDX-40] printer icon.

**If You're Using Windows XP/2000**

Click [Printing Preferences].

**If You're Using Windows 98/Me**

Click [Properties].

③



Click the [Option] tab.

Click the [OPERATION PANEL] button.

The operation panel screen open.

## Switching Off the Power

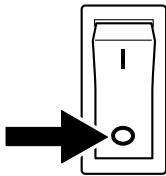

Switch off the main power switch.

The POWER light goes dark and the power to the machine is switched off.

## 3-2 Emergency Stop to Ensure Safety

### Emergency stop switch

This switch stops the machine in an emergency in order to avoid danger. Pressing the emergency stop switch immediately halts operation and aborts cutting.

#### How to Perform an Emergency Stop

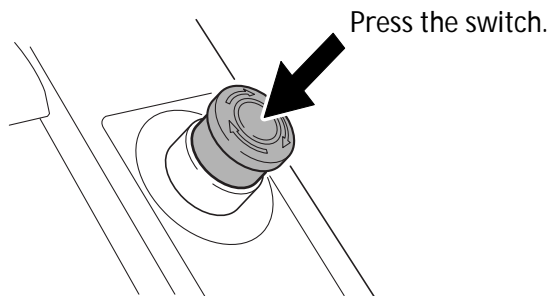

#### Releasing the Emergency Stop Switch

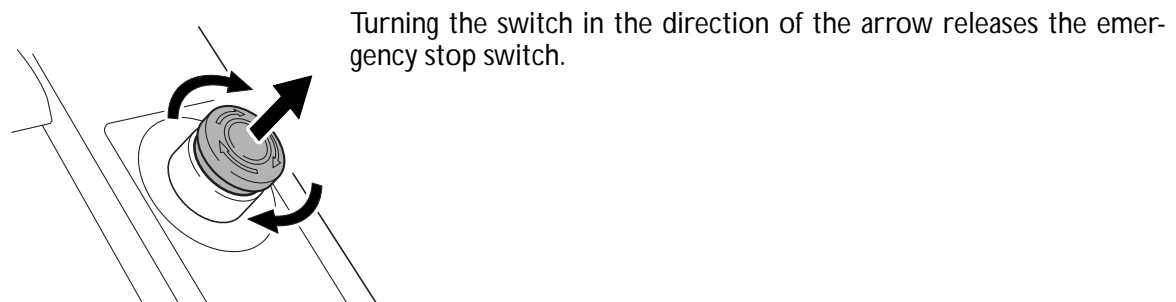

### Front Cover

For safety, opening the front cover during operation stops cutting and makes the MODELING and VIEW lights flash. To recover from this, close the front cover and switch off the sub power button. It is possible to open the front cover while the machine is paused. When the front cover is open, the VIEW light flashes every two seconds. Closing the cover stops the flashing.

☞ P.34 "Stopping and Pausing Cutting"



## 3-3 Installing a Tool and Setting the Cutting-start Location

### The Locations of the Origin Points

When you perform cutting using a work plate, you set three origin points: the X, Y, and Z origins. The X and Y origin points serve as the start location for cutting. You normally align the Z origin point with the surface of the workpiece. In any case, make the settings to match the size of the workpiece and the length of the cutter.

### Installing a Tool

**⚠ CAUTION** Do not touch the tip of the blade with your fingers. Doing so may result in injury.

- 1 Close the front cover.  
Press the VIEW button to make the VIEW light come on.  
The table moves back toward you.
- 2 Wait until operation has stopped completely, then open the front cover.
- 3

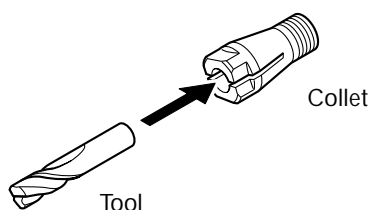

Insert the tool into the collet.

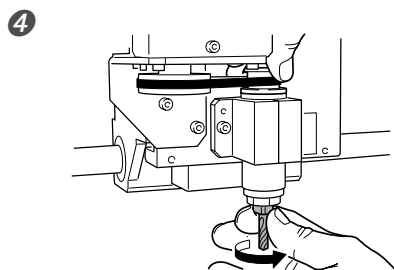

Insert the collet chuck and tool from underneath. While supporting the tool to keep it from falling, turn the collet chuck to secure it in place.

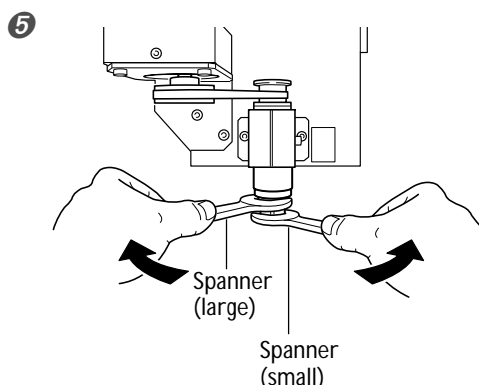

Tighten the collet using spanners.

## Setting the Cutting-start Location

### 1. Set the Z origin point.

- 1 Close the front cover.  
Press the VIEW button to make the VIEW light go out.

- 2  Using the operation panel screen, press the button in the figure.

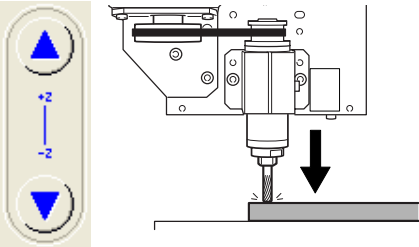
- 3  Bring the tool lightly into contact with the surface of the workpiece while rotating the spindle.  
Workpiece

- 4  At the location where the workpiece surface begins to be cut slightly, stop rotating the spindle.

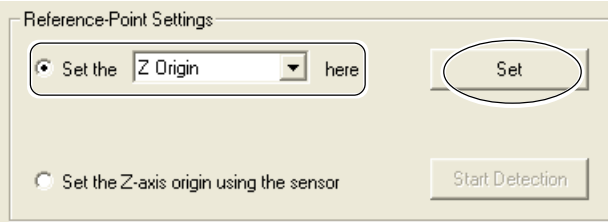
- 5  Select [Set the Z origin here].  
Click [Set].  
The Z origin point has now been set.

### 2. Set the XY origin point.

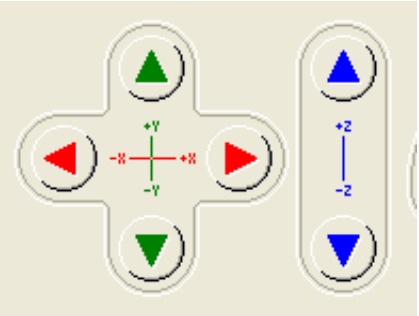
- 1  Move the spindle to the cutting-start location.  
Move the spindle to a location slightly above the workpiece.

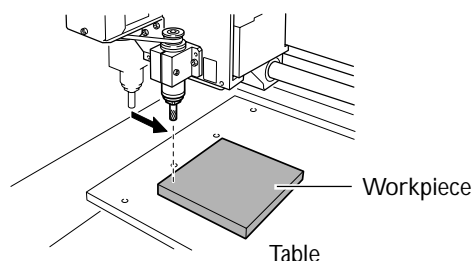

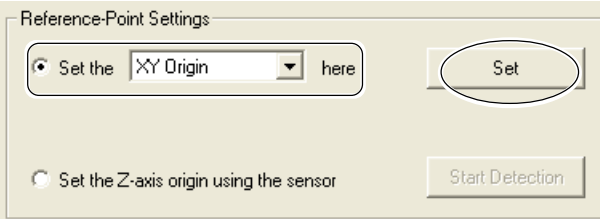
- 2  Select [Set the XY origin here].  
Click [Set].  
The XY origin point has now been set.

# 3-4 Starting Cutting

**⚠ CAUTION** Perform dry cutting with no cutting oil.  
Such materials can cause fire.

**⚠ CAUTION** Never operate if a front cover is cracked or broken.  
Doing so may result in injury. If the front cover is cracked, contact your authorized.

## Procedure

---

①

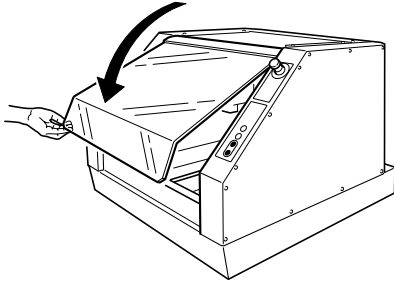

Close the front cover.

②



If the VIEW light is on, press the VIEW button to make the light go dark.

③ Send the cutting data from the computer.

# 3-5 Stopping and Pausing Cutting

## Pausing Cutting



Press the VIEW button.

Pressing the VIEW button moves the spindle to the left edge and the table to the front of the machine.

It is possible to open the front cover while the machine is paused. Before you open the front cover, make sure that operation has stopped completely.

To resume cutting, make sure the front cover is closed, then press the VIEW button again.

## Stopping Cutting

1



Press the VIEW button.

2

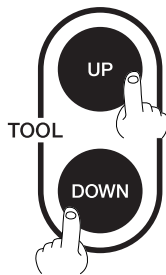

Press the TOOL-UP/TOOL-DOWN buttons at the same time.

The VIEW light flashes, and deletion of the data sent to the machine begins. When deletion of the data ends, the VIEW light stops flashing.

# ***Chapter 4***

## ***Feature Reference***

---

# 4-1 Setting the Z Origin Using the Sensor

## Setting the Z origin on the Workpiece

### 1. Mount the sensor.

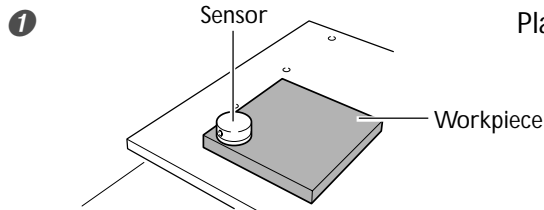

Place the sensor on the workpiece.

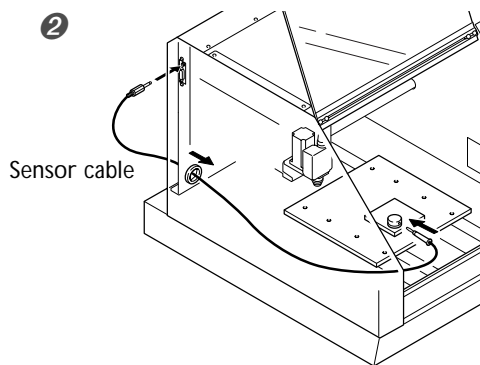

Run the sensor cable around behind the machine to the top of the table. Connect the sensor cable to the sensor connector.

### 2. Set the Z origin point.

- ① Close the front cover.  
Press the VIEW button to make the VIEW light go out.

- ② Using the operation panel screen, move the tool to a location above the sensor.

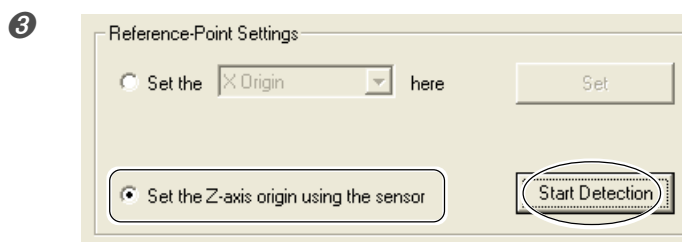
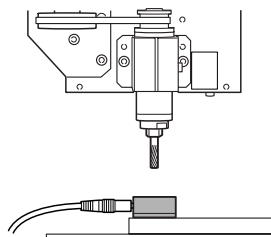
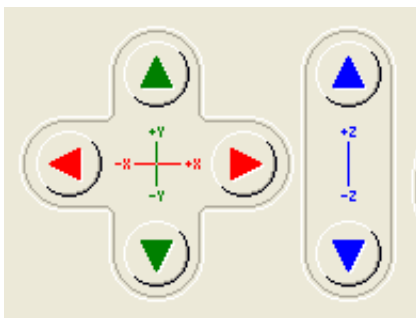

Select "Set the Z-axis origin using the sensor."  
Click "Start Detection."

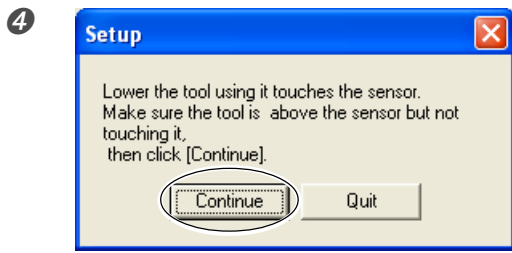

Click "Continue."

The cutter automatically makes contact with the sensor, and the Z-axis origin point is set the surface of the workpiece.

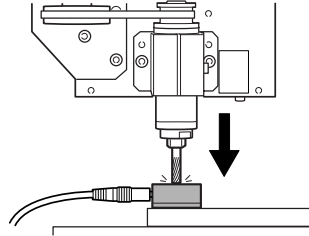

5 Detach the sensor and sensor cable.

# 4-2 Installing the Engraving Cutter

## Installing a Cutter and Setting the Origin Point for Machining

When using an engraving cutter, the optionally available engraving cutter and collet.

**⚠ CAUTION** Do not touch the tip of the blade with your fingers. Doing so may result in injury.

### 1. Installing a cutter and setting the Z point for machining.

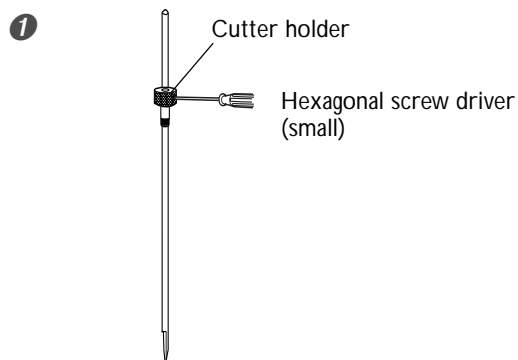

Detach the cutter holder from the cutter.

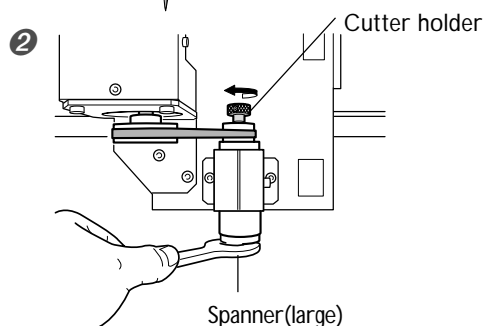

While using a spanner to hold the spindle immobile, tighten the cutter holder sufficiently.

The cutter holder is reverse-threaded (that is, you turn it counter-clockwise to tighten it). Be careful to turn it in the correct direction.

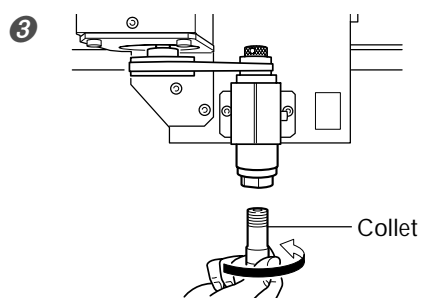

Insert the collet from underneath.

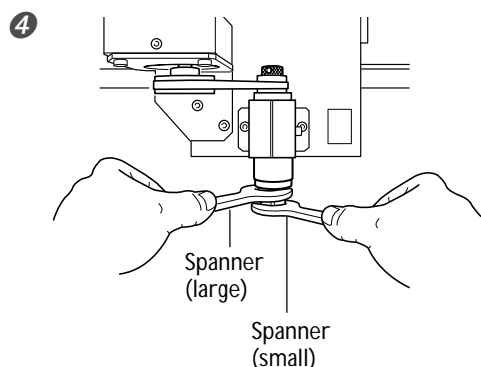

Tighten the collet using spanners.



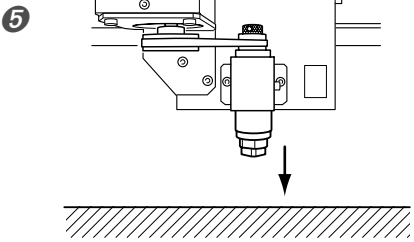

Lower the spindle and bring the tip of the collet close to the surface of the workpiece.

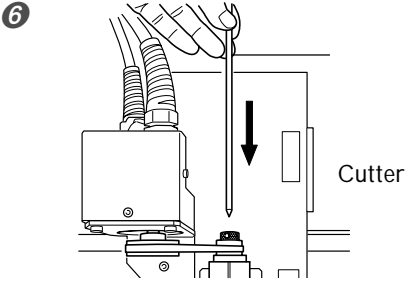

Insert the cutter.

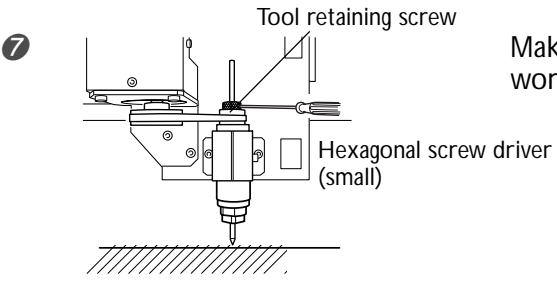

Making the tip of the cutter touch the surface of the workpiece, and tighten the tool retaining screw.

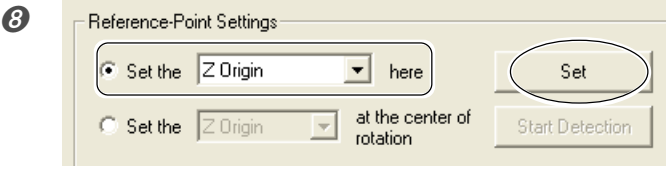

Using the operation panel screen, select [Set the Z origin here]. Click [Set]. The Z origin has now been set.

## 2. Make the setting for the XY origin point.

---

1

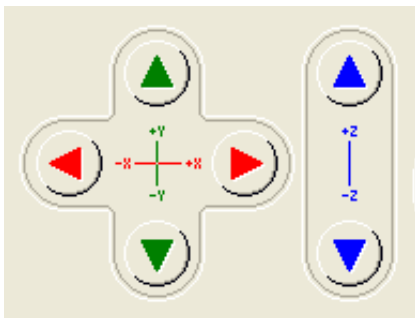

Using the operation panel screen, move the spindle to the cutting-start location.

2

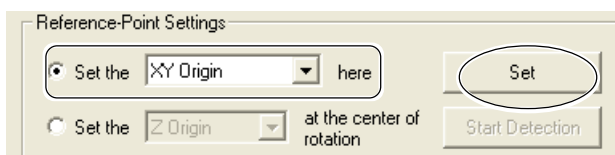

Select [Set the XY origin here].  
Click [Set].  
The XY origin has now been set.

# *Chapter 5*

## *Appendix*

---

# 5-1 Maintenance

## Daily Care

This section describes the maintenance methods for day-to-day care of the machine.

- ⚠WARNING**    **Never use an air gun (blower) to remove cuttings.**  
Using an air gun (blower) may blow cuttings inside the machine, creating a fire hazard.
- ⚠WARNING**    **Never use gasoline, alcohol, thinner, or any other flammable material.**  
Doing so may cause fire.
- ⚠CAUTION**    **Switch off the machine and unplug the power cord from the electrical outlet before performing cleaning or maintenance.**  
Failure to do so may result in injury or electrical shock.
- ⚠CAUTION**    **Do not touch the spindle motor immediately or cutter after a cutting operation has ended.**  
Doing so may result in burns.
- ⚠CAUTION**    **Use a brush to remove cuttings.**  
Attempting to use a vacuum cleaner to take up cuttings may cause fire in the vacuum cleaner.

- This machine is a precision device, and is sensitive to dust and dirt. Perform cleaning on a daily basis.
- Never use a solvent such as thinner or benzine.
- Clean cuttings carefully.
- To clean the cover, use a dry cloth to wipe it.
- Never attempt to oil or lubricate the machine.

## Spindle Inspection

The spindle unit and the belt are parts that wear out. As a general guide, you should replace them after every 2,000 hours of use.

As a general guide, replace the spindle motor after every 6,000 hours of use.

# 5-2 What to Do If

## The machine doesn't run.

### Is the power switched on?

Start the machine and make sure the POWER and MODELING lights come on.

☞ P.28 "Switching the Power On and Off"

### Is the front cover open?

Close the front cover.

### Is the VIEW light on?

When the VIEW light is on, operation is paused. When the VIEW light is on, cutting does not start even when data is sent. Press the VIEW button to cancel the paused state.

### Is the lights flashing an error message?

☞ P.43 "What to Do If a Flashing Error Is Displayed."

### Is a message displayed on the screen?

☞ P.43 "What to Do If an Error Message Appears."

### Is the cable connected?

Connect the cable securely.

## The cutting results are not attractive.

### Is the workpiece securely mounted in place?

Mount the workpiece in place securely, using the appropriate mounting method for the kind of cutting you're performing.

### Is the tool securely installed?

Retighten the collet to hold in place securely.

### Is the tip of the tool worn?

If the tip of the tool shows wear, then replace with a new tool.

## What to Do If a Flashing Error Is Displayed

If the lights are flashing as shown below, then an error has occurred on the machine. To correct the error, follow the steps described below.

---

### The MODELING and SCANNING lights

---

**An error occurred during initialization of the machine or during origin detection by the sensor.**

Switch the power off, then back on.

If the error is not cleared when you switch the power on again, the machine may be malfunctioning. Contact your authorized Roland DG Corp. dealer or service center.

---

### The MODELING and VIEW lights

---

**The front cover was opened while cutting was in progress.**

Operation cannot be continued. Close the front cover and press the sub power button.

---

### The MODELING light

---

**The spindle motor error occurred.**

Operation cannot be continued. Press the sub power button to clear the error. Make the program's cutting parameters more relaxed to lessen the load applied to the spindle.

## What to Do If an Error Message Appears

This section describes the error messages that may appear on the monitor of the computer you're using, and how to take action to remedy the problem. If the action described here does not correct the problem, or if an error message not described here appears, contact your vendor or the nearest Roland DG Corp. service center.

---

### [The machine is not responding.]

---

**The machine and the operation panel screen cannot communicate because the power to the machine has been interrupted or the USB cable has come loose.**

Start the machine, or make sure the USB cable is connected securely. After checking, open the operation panel screen again.

---

**[Operation or view in progress. Please wait until operation stops, or cancel the view.]**

---

**An attempt was made to perform an operation or make settings using the operation panel screen while the machine was either in operation or paused.**

The operation panel screen cannot be used to start a new operation or make new settings while an cutting operating is in progress or when the machine is paused. Either wait until the operation ends or cancel the paused state, then carry out the operation or make the settings.

---

**[No sensor is connected.]**

---

**The sensor was not connected to the machine during origin-detection operation.**

Make sure the sensor is installed on the machine and the connector is connected.

---

**[Emergency stop -- excess current to spindle. Please switch off machine power.]**

---

**An emergency stop occurred because the spindle experienced excessive load.**

Make the cutting parameters more relaxed, then carry out cutting again.

If this message appears even after you have changed the cutting parameters, then contact your authorized Roland DG Corp. dealer or service center.

---

**[Emergency stop -- voltage drop due to excessive spindle load.]**

---

**An emergency stop occurred because the voltage drop.**

Relax the cutting parameters, allow the machine cool down, then carry out cutting again.

If this message appears even after you have changed the cutting parameters and allowed the machine to cool, then contact your authorized Roland DG Corp. dealer or service center.

---

**[Emergency stop -- spindle driver IC overheated. Please switch off machine power.]**

---

**An emergency stop occurred because the spindle became too hot.**

Relax the cutting parameters, allow the machine cool down, then carry out cutting again.

If this message appears even after you have changed the cutting parameters and allowed the machine to cool, then contact your authorized Roland DG Corp. dealer or service center.

---

**[Emergency stop -- spindle motor overheated.]**

---

**An emergency stop occurred because the spindle motor became too hot.**

Relax the cutting parameters, allow the machine cool down, then carry out cutting again.

If this message appears even after you have changed the cutting parameters and allowed the machine to cool, then contact your authorized Roland DG Corp. dealer or service center.

---

**[X-axis [Y-axis/Z-axis/A-axis] limit-switch error. Please switch off machine power.]**

---

**An error occurred during initialization of the machine.**

This message may appear if head movement is obstructed during initialization at startup. Switch the power off, then back on.

---

**[Settings cannot be saved or read. Please switch off machine power.]**

---

**An error occurred either when setting the origin location or during startup after making the settings.**

The origin location could not be changed or set. Switch the power off and back on, then redo the setting for the origin location.

---

**[Emergency stop -- cover opened during operation. Please switch off machine power.]**

---

**The front cover was opened during cutting.**

Operation cannot be continued. To ensure safety, opening the front cover causes an emergency stop to occur. Switch the power off and back on, then redo the cutting.

---

**[Sensor error. Please switch off machine power.]**

---

**Origin detection using the sensor cannot be performed.**

Origin detection cannot be performed. Switch off the power and detach the connector for the sensor. Then switch the power back on and connect the connector for the sensor.

## 5-3 Locations of the Power Rating and Serial Number Labels

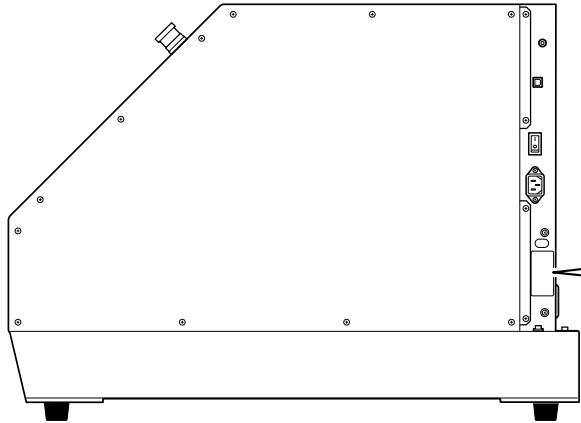

### **Serial Number**

This is require when you seek maintenance, servicing, or support. Never peel off the label or let it get dirty.

### **Power Rating**

Use an electrical outlet that meets the requirements for voltage, frequency, and amperage given here.

# 5-4 Specifications

## Main Unit Specification

		MDX-40
Acceptable material		Resins such as chemical wood and modeling wax(metal not supported)
X,Y, and Z operation strokes		305 (X) x 305 (Y) x 105 (Z) mm (12 (X) x 12 (Y) x 4-1/8 (Z) in.)
Distance from spindle tip to table		Maximum 125 mm (4-15/16 in.)
Table size		305 (W) x 305 (D) mm (12 (W) x 12 (D) in.)
Loadable workpiece weight		4 Kg (8.8 lb)
XYZ-axis motor		Stepping motor
Feed rate		XY-axis : 0.1 to 50 mm/sec. (0.0039 to 1.9 in./s) Z-axis : 0.1 to 30 mm/sec. (0.0039 to 1.1 in./s)
Software resolution		0.01 mm/step (0.00039 in./step)
Mechanical resolution		0.002 mm/step (0.0001 mm/step)
Spindle motor		DC brushless motor, Maximum 100W
Spindle type		Modeling spindle
Spindle rotation		4500 to 15000 rpm
Tool chuck		Cutter holder (4.36 mm)
Interface		USB connector, sensor connector, expansion connector
Power supply	Voltage and frequency	AC100 to 240 ± 10 %, 50/60 Hz
	Required power capacity	2.1 A
Power consumption		Approx. 210W
Acoustic noise level		No-load operation : 56 dB (A) or less, standby : 42 dB (A) or less (According to ISO7779)
Dimensions		669 (W) x 760 (D) x 554 (H) mm (26-3/8 (W) x 29-15/16 (D) x 21-13/16 (H) in.)
Weight		66 Kg (146 lb)
Packed dimensions		785 (W) x 885 (D) x 735 (H) mm (31 (W) x 35 (D) x 29 (H) in.)
Packed weight		73 Kg (161 lb)
Operation temperature		5 to 40°C (41 to 104°F)
Operation humidity		35 to 80 % (no condensation)
Accessories		Power cord, collet, sensor, hexagonal wrench, hexagonal screw drivers, spanners, Roland Software Package CD-ROM, MODELA Player4 CD-ROM, user's manual, Roland Software Package installation and setup guide, MODELA Player4 installation and setup guide



## Expansion Connector Specification

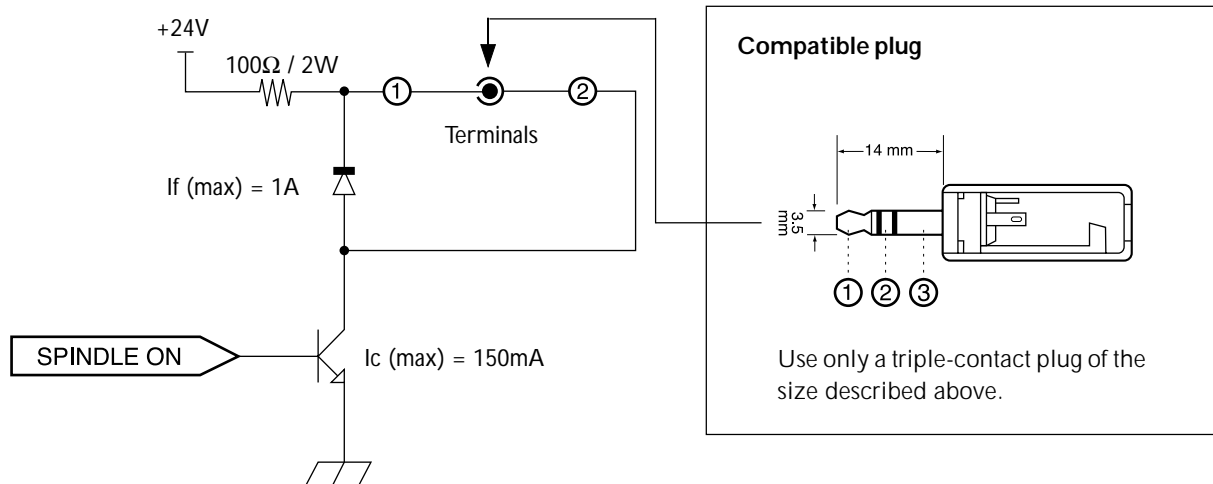

This circuit is activated when the spindle motor is in operation.

### About expansion connector specification

- Use within the rated range shown above.
- Do not apply voltage greater than 24 V to the terminal.
- Do not short the terminal to ground.

### About compatible plug

Do not use terminal ③. Use only terminals ① and ②.

No responsibility is assumed for effects to which any equipment connected to this external output connector is subjected.

No responsibility is assumed for malfunction when using any equipment connected to this external output connector is subjected.





## Please read this agreement carefully before opening the sealed package or the sealed disk package

Opening the sealed package or sealed disk package implies your acceptance of the terms and conditions of this agreement.

### Roland License Agreement

Roland DG Corporation ("Roland") grants you a non-assignable and non-exclusive right to use the COMPUTER PROGRAMS in this package ("Software") under this agreement with the following terms and conditions.

- 1. Coming into Force**                      This agreement comes into force when you purchase and open the sealed package or sealed disk package.  
The effective date of this agreement is the date when you open the sealed package or sealed disk package.
- 2. Property**                                      Copyright and property of this Software, logo, name, manual and all literature for this Software belong to Roland and its licensor.

The followings are prohibited :

  - (1) Unauthorized copying the Software or any of its support file, program module or literature.
  - (2) Reverse engineering, disassembling, decompiling or any other attempt to discover the source code of the Software.
- 3. Bounds of License**                      Roland does not grant you to sub-license, rent, assign or transfer the right granted under this agreement nor the Software itself (including the accompanying items) to any third party.  
You may not provide use of the Software through time-sharing service and/or network system to any third party who is not individually licensed to use this Software.

You may use the Software by one person with using a single computer in which the Software is installed.
- 4. Reproduction**                              You may make one copy of the Software only for back-up purpose. The property of the copied Software belongs to Roland.  
You may install the Software into the hard disk of a single computer.
- 5. Cancellation**                              Roland retains the right to terminate this agreement without notice immediately when any of followings occurs :

  - (1) When you violate any article of this agreement.
  - (2) When you make any serious breach of faith regarding this agreement.
- 6. Limitations on Liability**                      Roland may change the specifications of this Software or its material without notice.

Roland shall not be liable for any damage that may caused by the use of the Software or by exercise of the right licensed by this agreement.
- 7. Governing Law**                              This agreement is governed by the laws of Japan, and the parties shall submit to the exclusive jurisdiction of the Japanese Court.



26015516 - R1

R1-041018